

**Triple Constellations GNSS Module for
GPS/GLONASS/Galileo satellites****PGL-1612 Specification**

Version 1.0

2022/02/07

This document contains information highly confidential to KNCTEK Company LTD (KNCTEK). It is provided for the sole purpose of the business discussions between specific Users and KNCTEK and is covered under the terms of the applicable Non-Disclosure Agreements. Disclosure of this information to other parties is prohibited without the written consent of KNCTEK.

KNCTEK Company LTD.**6F03, Ace High-End Tower 6th, 60-25,
Gasan-dong, Geumcheon-gu****SEOUL, KOREA****TEL: 82-2-839-5701****FAX: 82-2-830-5703****E-Mail: knc3@knctek.co.kr****<http://www.knctek.co.kr>**

PGL-1612 Specification

REVISION HISTORY	3
INTRODUCTION	4
PRODUCT FEATURES	4
PRODUCT APPLICATIONS	4
PRODUCT PICTURE	5
PGL-1612 SYSTEM BLOCK DIAGRAM	5
TECHNICAL SPECIFICATION	6
RECOMMENDED GPS/GLONAS/Galileo ACTIVE EXTERNAL ANTENNA	8
MECHANICAL PIN LAYOUT	9
RECOMMENDED LAND PATTERN DIMENSION.....	9
HARDWARE INTERFACE	10
DEFINITION OF PIN ASSIGNMENT	11
PACKING INFORMATION	14
GPS/GLONASS/Galileo RECEIVER USER'S TIP	15
NMEA PROTOCOL	16
CONTACT INFORMATION SECTION	25

Revision History

1. 2022-02-07 : Initiated Version 1.0.

PGL-1612 Operational Manual

INTRODUCTION

The **PGL-1612** is the newest generation of KNCTEK' Triple Constellation GPS/GLONASS/Galileo Module. The Triple Constellation GPS/GLONASS/Galileo Module is powered by SkyTraq technology and KNCTEK proprietary navigation algorithm that provide you more stable navigation data. The miniature design is the best choice to be embedded in a portable device various Trackers, Vehicle & personal Locaters and etc. The excellent sensitivity of **PGL-1612** gets the great performance when going though the urban canyon and foliage environmental condition.

PRODUCT FEATURES

- ✧ GPS, GLONASS, Galileo, QZSS, SBAS(WAAS, MSAS, EGNOS, GAGAN) supported
- ✧ 230 Acquisition & Tracking Channels
- ✧ Operable from 3.3V/Typ 62mA for Acquisition and 48mA for Tracking Mode
- ✧ Signal Detection better than -165dBm in Ultra High Tracking Sensitivity
- ✧ Enhanced Cold Acquisition Sensitivity at -148dBm and Reacquisition at -160dBm
- ✧ 28 seconds Warm start and 29 seconds Cold start TTFF under open sky average
- ✧ Advanced Multipath detection and suppression
- ✧ Jamming detection and mitigation
- ✧ SAEE(Self-aided ephemeris estimation) Supported
- ✧ Excellent Sensitive for Urban Canyon and Foliage Environmental condition
- ✧ NMEA-0183 compliant protocol
- ✧ Automotive-grade Quality GPS solution
- ✧ Small form factor (16X12.2X2.4mm)
- ✧ ODM/OEM development is fully supported Application Engineering
- ✧ RoHS compliant

PRODUCT APPLICATION

- ✧ Automotive applications
- ✧ Speed camera detector and Data logger
- ✧ Personal and Car Navigation Devices
- ✧ Marine navigation
- ✧ Timing application and the others

PRODUCT PICTURE



PGL-1612 SYSTEM BLOCK DIAGRAM

The PGL-1612 consists of SkyTraQ chipsets Technology, KNCTEK LNA and proprietary software. The system is described as follows.

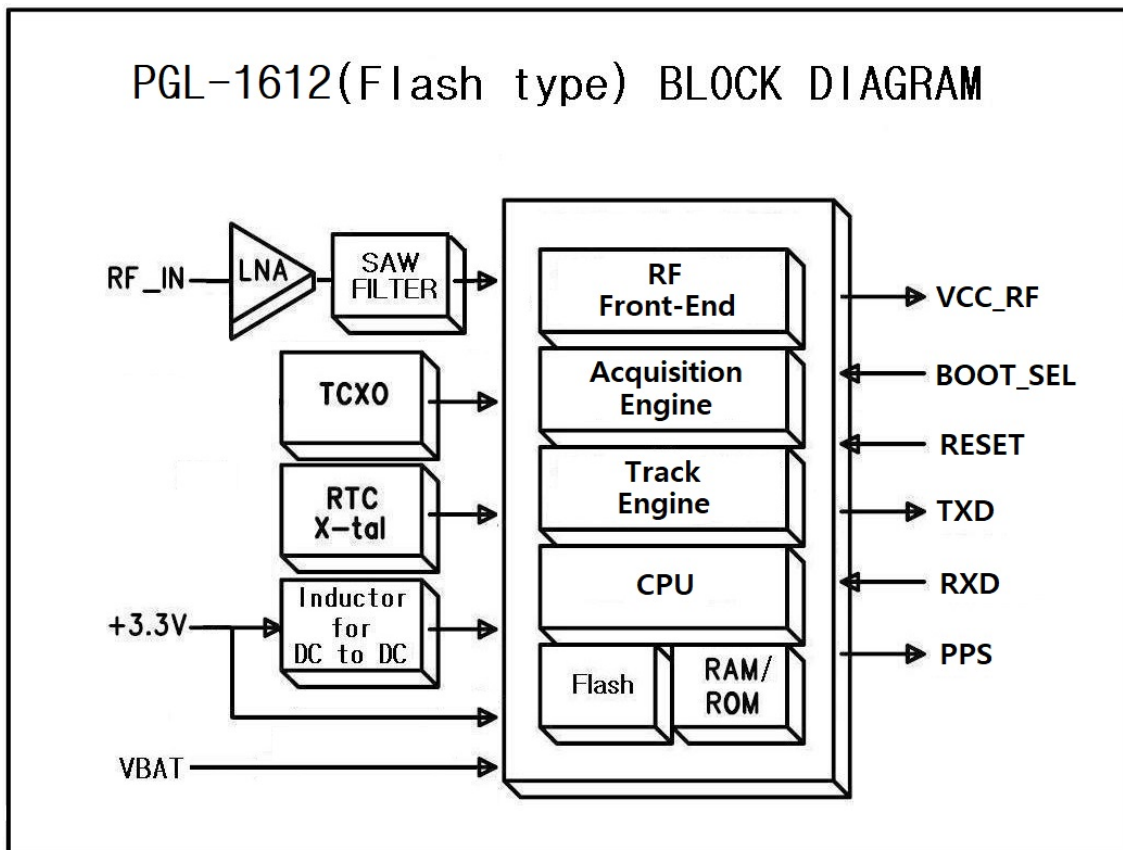

TECHNICAL SPECIFICATION

1. Electrical Characteristics

1.1 Absolute Maximum Rating

Parameter	Symbol	Min	Max	Units
Power Supply				
Power Supply Volt.	VCC	-0.3	3.6	V
Input Pins				
Input Pin Voltage I/O	RX	-0.3	3.6	V
Backup Battery	Vbat	-0.3	3.6	V
Environment				
Operating Temperature	Topr	-30	85	°C
Storage Temperature	Tstg	-40	85	°C
Peak Reflow Soldering Temperature < 10S	Tpeak		260	°C

Note : Absolute maximum ratings are stress ratings only, and functional operation at the maximums is not guaranteed. Stress beyond the limits specified in this table may affect device reliability or cause permanent damage to the device.

For functional operating conditions, please refer to the operating conditions tables as follow.

1.2 Operating Condition

Parameter	Symbol	Condition	Min	Typ	Max	Units
Power supply voltage	Vcc		3.0	3.3	3.6	V
Power Supply voltage ripple	Vcc_PP	Vcc = 3.3V			50	mV
Acquisition current	IccA	Vcc = 3.3V		62		mA
Tracking current	IccT	Vcc = 3.3V		48		mA
Input high voltage	V _{IH}		2.0			V
Input low voltage	V _{IL}				0.8	V
Output high voltage	V _{OH}		2.4			V
Output low voltage	V _{OL}				0.4	V

2. General Performance Specification

Parameter	Specification
Receiver Type	GPS/GLONASS/Galileo, 230 Acquisition & Tracking Channels
Sensitivity	Tracking -165dBm Re-acquisition -160dBm Cold Start -148dBm
Accuracy	Position 2.0m CEP Velocity 0.1m/s Timing(PPS) 12ns RMS
Acquisition Time	Cold Start 29 sec. typical (Open sky ¹) Warm Start 28 sec. typical (Open sky) Hot Start 1 sec. typical (Open sky) Reacquisition Time 1 sec(Open sky, re-appear after some seconds)
Power Consumption	Tracking 48mA @ 3.3V Acquisition 62mA @ 3.3V Back-up 15uA @ 3V
Navigation Data Update Rate	1Hz_Default In case of using Binary input : Max 25Hz ** Please refer to the Binary Input Message
Operational Limits	Velocity Max 515 m/s Altitude Max 18,000m Acceleration Less than 4g(39.2m/sec ²)
Mechanical data	Dimension 16.0 X 12.2 X 2.4mm (+/- 0.3mm) Weight 1.0grams ±5%
Protocol	NMEA-0183 V3.01 GNGGA 1Hz GNGLL 1Hz GNGSA 1Hz GPGSV 1/3Hz(one time per 3sec) GLGSV 1/3Hz GAGSV 1/3Hz GNRMC 1Hz GNVTG 1Hz GNZDA 1Hz

** ¹Open Sky means no obstructions in the sky

RECOMMENDED GPS/GLONASS/Galileo ACTIVE EXTERNAL ANTENNA

It's recommended to use a GPS/GLONASS/Galileo active external antenna with supply voltage of 3.3VDC and a current draw of 20mA maximum. The quality of the GPS/GLONASS/Galileo active external antenna chosen is of paramount importance for the overall sensitivity of the GPS/GLONASS/Galileo system. A GPS/GLONASS/Galileo active external antenna should have a typical gain 20dB and a noise figure ≤ 1.5 dB, which applies to more than 90% of the antennas available in the market.

3.3V GPS/GLONASS/Galileo Active External Antenna Specification

Characteristics	Specification
Center Frequency	GPS/Galileo : 1575.42MHz, GLONASS : 1602 \pm 4MHz
Gain at Zenith	2.0dBi Typical
VSWR	2.0 : 1 Max
Polarization	R.H.C.P
Gain	Typical 20dB(>15dB)
Noise Figure	Less than 1.5dB
Out Band Attenuation	20dB min for \pm 50MHz
Voltage	3.3 \pm 10%VDC or 3.0 ~ 3.6 VDC
Current	≤ 20 mA

MECHANICAL PIN LAYOUT

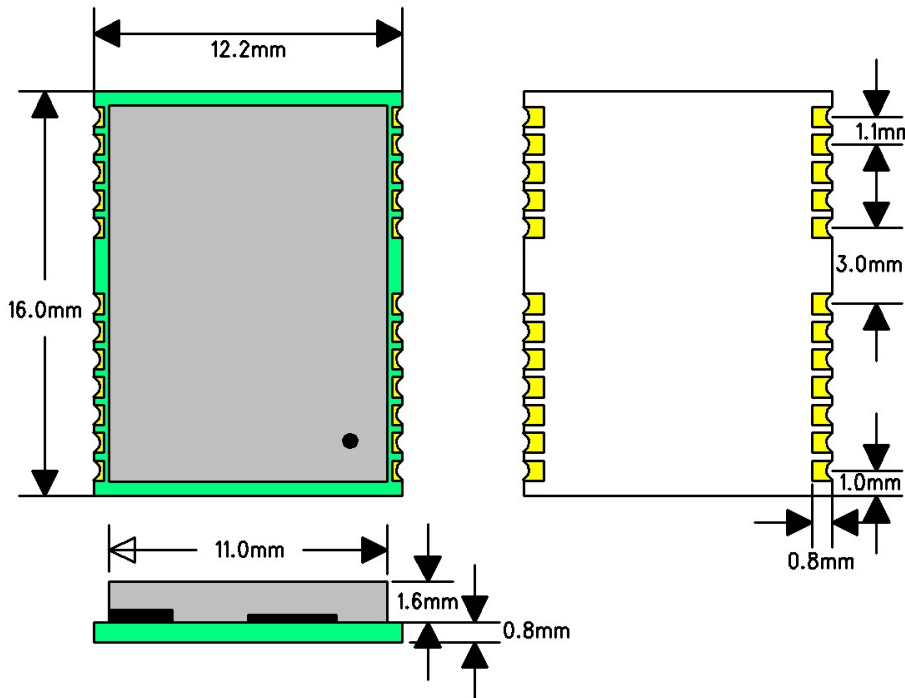

RECOMMENDED LAND PATTERN DIMENSION

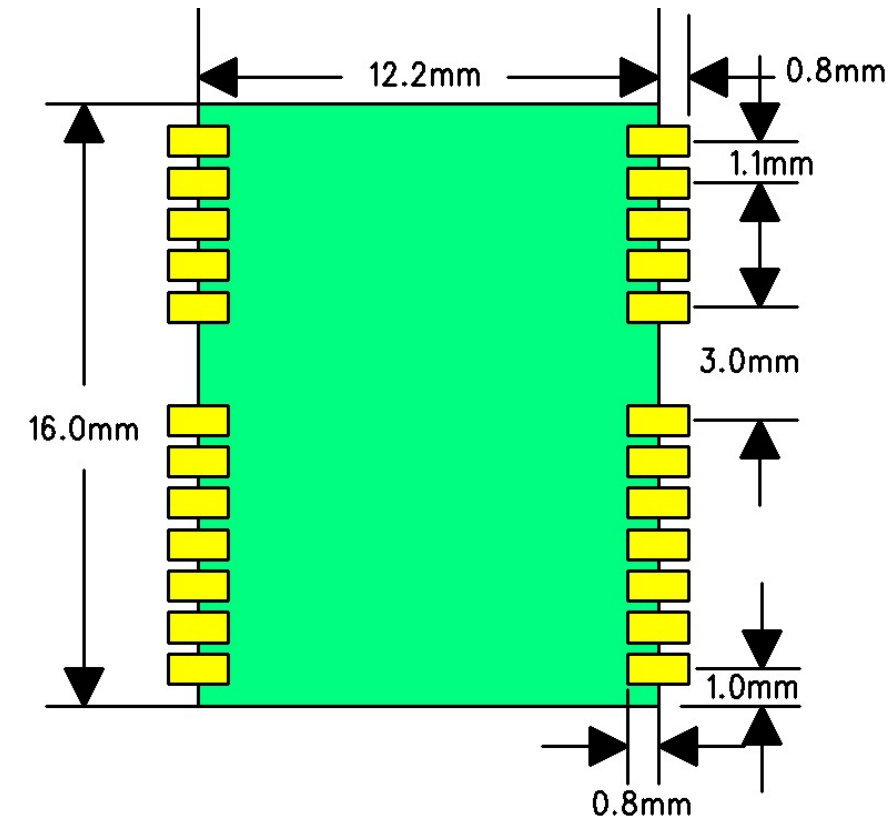

HARDWARE INTERFACE

1. Example 1 for GPS/GLONASS/Galileo External Active Antenna

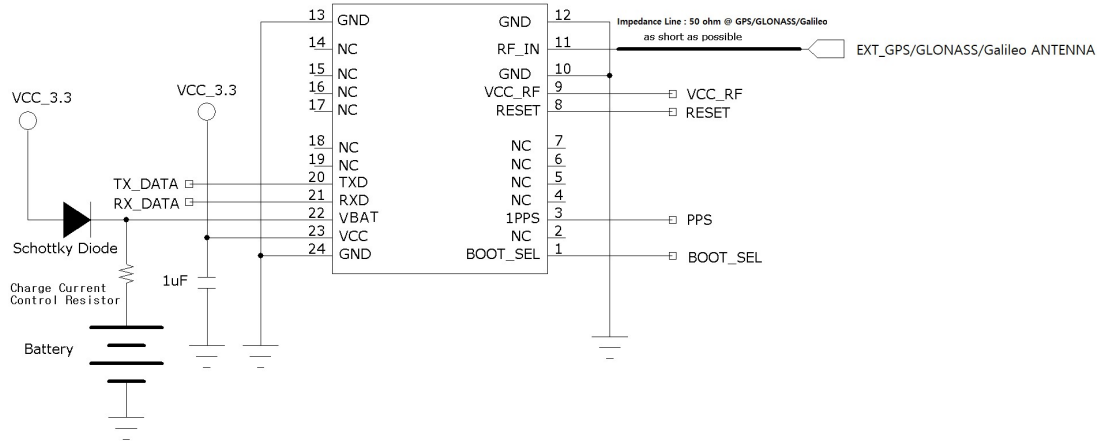

2. Example 1 for GPS/GLONASS/Galileo Patch Antenna

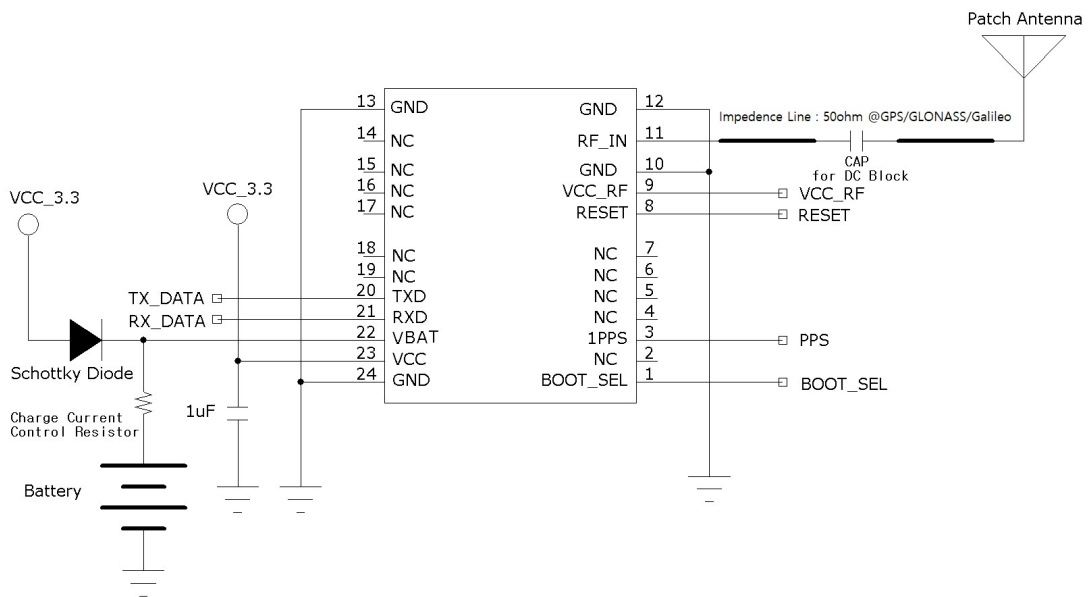

DEFINITION OF PIN ASSIGNMENT

PIN	SIGNAL NAME	I/O	DESCRIPTION	CHARACTER
1	BOOT_SEL	I	BOOT MODE SELECTION,	No connection for normal use
2	NC	–	Not connecting	
3	1PPS	O	One Pulse per Second	When getting 3D position fix, output is ok
4	NC	–	Not connecting	
5	NC	–	Not connecting	
6	NC	–	Not connecting	
7	NC	–	Not connecting	
8	RESET	I	RESET (Active LOW)	Active LOW
9	VCC_RF	O	Voltage output of VCC_RF	Output voltage for Active Antenna
10	GND	GND	Ground	
11	RF_IN	I	GPS/GLONASS/Galileo SIGNAL INPUT	50Ω Impedance Line @ GPS/GLONASS/Galileo / 3.2V Bias output for Active Antenna
12	GND	GND	Ground	
13	GND	GND	Ground	
14	NC	–	Not connecting	
15	NC	–	Not connecting	
16	NC	–	Not connecting	
17	NC	–	Not connecting	
18	NC	–	Not connecting	
19	NC	–	Not connecting	
20	TXD	O	NMEA_TX : UART output	3.3V LVTTTL
21	RXD	I	NMEA_RX : UART input	3.3V LVTTTL
22	VBAT	I	Backup Battery supply, must not be unconnected	DC +1.3V ~ +3.6V
23	VDD	I	DC Power Supply Voltage input	DC +3.3V ±10%
24	GND	GND	Ground	

BOOT_SEL

This is selection for uploading firmware into empty or corrupted Flash memory from ROM mode. No connection for normal use.

1PPS

This pin is one pulse per second time-mark output, 3.3V LV-TTL.

The rising edge synchronized to UTC second when getting 3D position fix. The pulse duration is about 100msec at rate 1Hz.

RESET

This is the function to restart the system, If the pin is lied to low.

Only needed when power supply rise time is very slow or software controlled reset is desired.

Leave unconnected if not used.

VCC_RF

This is pin for supplying voltage of external GPS/GLONASS/Galileo Active Antenna.

RF_IN

The Module supports passive & active antennas. The line on the PCB from the antenna(or antenna connector)has to be a controlled line (Micro strip at 50Ω @ GPS/GLONASS/Galileo signal).

The input provides also a bias supply(+3.2V typ.).

TXD

UART serial data output, 3.3V LVTTTL logic level. This is the main transmit channel and is normally used for sending position, time and velocity information from the receiver in NMEA-0183 format. The default setup is NMEA Output, 9600bps, 8 data bits, no parity, 1 stop bit. The default sentences are GNGGA, GNGLL, GNGSA, GPGSV, GLGSV, GAGSV, GNRMC, GNVTG, GNZDA.

GNGGA, GNGLL, GNGSA, GNRMC, GNVTG, GNZDA are once per second and GPGSV, GLGSV, GAGSV is once per 3 second.

RXD

UART serial data input, 3.3V LVTTTL logic level. This is the main receiving channel and is used to receive software commands to the Engine board from user written software.

VBAT

This is the battery backup supply that powers the SRAM and RTC when main power is removed. The input voltage level is from 1.3V ~ 3.6V. Without an external backup battery or on board battery, engine board will execute a cold start after every turn on. To achieve the faster start-up offered by a hot or warm start, either a backup battery must be connected or battery installed on board. **This pin must be connected by power(normal Input power)for operating, must not be unconnected.**

VDD(DC Power Input)

This is the main power supply for the Engine board. The power range is from 3.3V \pm 10%(the maximum and minimum voltage is 3.0V to 3.6V). Suitable decoupling must be provided by external decoupling circuitry.

GND

GND provides the ground for the Engine board. Connect all grounds.

Packing Information

1. Carrier Tape Dimension

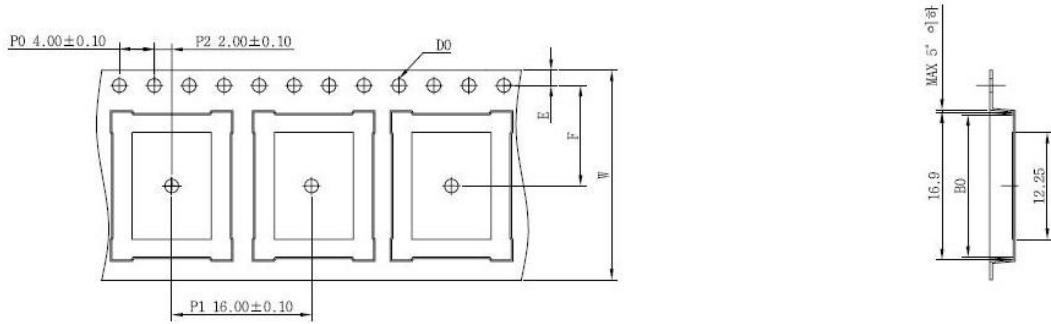

Taping style

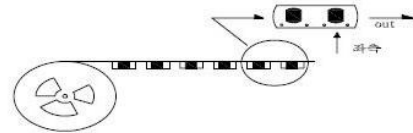
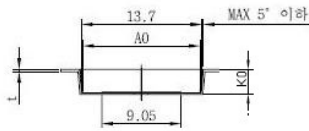

A0	13,40±0,10	E	1,75±0,10
B0	16,60±0,10	F	11,50±0,10
K0	2,70±0,10	t	0,30±0,05
D0	1,55±0,05	w	24,00±0,30

2. Inner & Out Box (Carton Box)

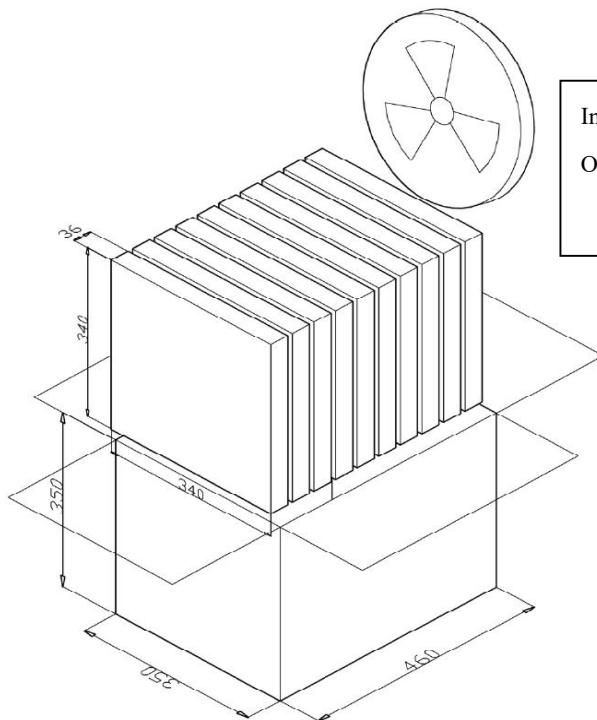

Inner Box : 1,500pcs by one Tape & Reel packing
 Out Box : Contained 10sets of Inner Boxes.
 (Total 15,000pcs)

GPS/GLONASS/Galileo Receiver User's Tip

1. GPS/GLONASS/Galileo signal will be affected by weather and environment conditions, thus suggest you to use the GPS/GLONASS/Galileo receiver under less shielding environments to ensure GPS/GLONASS/Galileo receiver has better receiving performance.
2. When GPS/GLONASS/Galileo receiver is moving, it will prolong the time to fix the position, so suggest to wait for the satellite signals to be locked at a fixed point when first power-on the GPS/GLONASS/Galileo receiver to ensure to lock the GPS/GLONASS/Galileo signal at the shortest time.
3. The following situation will affect the GPS/GLONASS/Galileo receiving performance:
 - a. Solar control filmed windows.
 - b. Metal shielded, such as umbrella, or in vehicle.
 - c. Among high buildings.
 - d. Under bridges or tunnels.
 - e. Under high voltage cables or nearby radio wave sources, such as mobile phone base stations.
 - f. Bad or heavy cloudy weather.
4. If the satellite signals cannot be locked or encounter receiving problem (while in the urban area), the following steps are suggested:
 - a. Please plug the external active antenna into GPS/GLONASS/Galileo receiver and put the antenna on outdoor or the roof of the vehicle for better receiving performance.
 - b. Move to another open space or reposition GPS/GLONASS/Galileo receiver toward the direction with fewer blockages.
 - c. Move the GPS/GLONASS/Galileo receiver away from the interference resources.
 - d. Wait until the weather condition is improved.

While a GPS/GLONASS/Galileo with a backup battery, the GPS/GLONASS/Galileo receiver can fix a position immediately at next power-on if the build-in backup battery is full-recharged.

NMEA Protocol Overview

The output protocol supports NMEA-0183 standard. The implemented message include GGA, GLL, GSA, GSV, VTG, RMC, ZDA messages. The NMEA message output has the following sentence structure:

\$aacc,c-c*hh<CR><LF>

The detail of the sentence structure is explained in Table 1.

Table 1 : The NMEA sentence structure

character	HEX	Description
"\$"	24	Start of sentence
Aaacc		Address field. "aa" is the talked identifier. "ccc" identifies the sentence type
","	2C	Field delimiter
C-c		Data sentence block
"*"	2A	Checksum delimiter
Hh		Checksum field.
<CR><LF>	0D0A	Ending of sentence. (carriage return, line feed)

Table 2 : Overview of NMEA messages

\$GNGGA	Time, position, and fix related data of the receiver.
\$GNGLL	Position, time and fix statue.
\$GNGSA	Used to represent the ID's of satellites which are used for position fix. When GPS satellites are used for position fix, \$GNGSA sentence is output with system ID 1. When GLONASS satellites are used for position fix, \$GNGSA sentence is output with system ID 2. When Galileo satellites are used for position fix, \$GNGSA sentence is output with system ID 3.
\$GPGSV \$GLGSV \$GAGSV	Satellite information about elevation, azimuth and CNR, \$GPGSV is used for GPS satellites, while \$GLGSV is used of GLONASS satellites, while \$GAGSV is used of Galileo satellites
\$GNRMC	Time, date, position, course and speed data.
\$GNVTG	Course and speed relative to the ground
\$GNZDA	UTC, day, month and year and time zone.

GGA - Global Positioning System Fix Data

Time, position and fix related data for a GPS receiver.

Structure:

```
$--GGA,hhmmss.sss,ddmm.mmmmm,a,dddmm.mmmmm,a,x,xx,x.x,x.x,M,x.x,M,x.x,xxxx*hh<CR><LF>
```

1 2 3 4 5 6 7 8 9 10 11 12 13

Example:

```
$GNGGA,111636.932,2447.09495,N,12100.52235,E,1,11,0.8,118.2,M,21.3,M,,0000*02<CR><LF>
```

Field	Name	Example	Description
1	UTC Time	111636.932	UTC of position in hhmmss.sss format, (000000.000 ~ 235959.999)
2	Latitude	2447.09495	Latitude in ddmm.mmmmm format Leading zeros transmitted
3	N/S Indicator	N	Latitude hemisphere indicator, 'N' = North, 'S' = South
4	Longitude	12100.52235	Longitude in dddmm.mmmmm format Leading zeros transmitted
5	E/W Indicator	E	Longitude hemisphere indicator, 'E' = East, 'W' = West
6	GPS quality indicator	1	GPS quality indicator 0: position fix unavailable 1: valid position fix, SPS mode 2: valid position fix, differential GPS mode 3: GPS PPS Mode, fix valid 4: Real Time Kinematic. System used in RTK mode with fixed integers 5: Float RTK. Satellite system used in RTK mode. Floating integers 6: Estimated (dead reckoning) Mode
7	Satellites Used	11	Number of satellites in use, (00 ~ 24)
8	HDOP	0.8	Horizontal dilution of precision, (00.0 ~ 99.9)
9	Altitude	108.2	mean sea level (geoid), (-9999.9 ~ 17999.9)
10	Geoidal Separation	21.3	Geoidal Separation in meters
11	Age of Differential GPS data	0000	Age of Differential GPS data NULL when DGPS not used

12	DGPS Station ID	0000	Differential reference station ID, 0000 ~ 1023
13	Checksum	02	

GLL – Latitude/Longitude

Latitude and longitude of vessel position, time of position fix and status.

Structure:

\$--GLL,ddmm.mmmmm,a,dddmm.mmmmm,a,hhmmss.sss,A,a*hh<CR><LF>

1 2 3 4 5 6 7 8

Example:

\$GNGLL,2447.09495,N,12100.52235,E,112609.932,A,A*57<CR><LF>

Field	Name	Example	Description
1	Latitude	2447.09495	Latitude in ddmm.mmmmm format Leading zeros transmitted
2	N/S Indicator	N	Latitude hemisphere indicator 'N' = North 'S' = South
3	Longitude	12100.52235	Longitude in dddmm.mmmmm format Leading zeros transmitted
4	E/W Indicator	E	Longitude hemisphere indicator 'E' = East 'W' = West
5	UTC Time	112609.932	UTC time in hhmmss.sss format (000000.000 ~ 235959.999)
6	Status	A	Status, 'A' = Data valid, 'V' = Data not valid
7	Mode Indicator	A	Mode indicator 'N' = Data not valid 'A' = Autonomous mode 'D' = Differential mode 'E' = Estimated (dead reckoning) mode
8	Checksum	57	

GSA – GNSS DOP and Active Satellites

GNSS receiver operating mode, satellites used in the navigation solution reported by the GGA or GNS sentence and DOP values.

Structure:

```
$--GSA,A,x,xx,xx,xx,xx,xx,xx,xx,xx,xx,xx,xx,x.x,x.x,x.x*hh<CR><LF>
    1 2 3 3 3 3 3 3 3 3 3 3 3 3 4 5 6 7
```

Example:

```
$GNGSA,A,3,05,12,21,22,30,09,18,06,14,01,31,,1.2,0.8,0.9*36<CR><LF>
$GNGSA,A,3,69,70,73,79,80,,,,,,,,,1.2,0.8,0.9*3C<CR><LF>
```

Field	Name	Example	Description
1	Mode	A	Mode 'M' = Manual, forced to operate in 2D or 3D mode 'A' = Automatic, allowed to automatically switch 2D/3D
2	Mode	3	Fix type 1 = Fix not available 2 = 2D 3 = 3D
3	Satellite used 1~16	05,12,21,22,30,09,18,06,14,01,31,,	Satellite ID number, 01 ~ 32 are for GPS; 33 ~ 64 are for WASS(PRN minus 87); 193 ~ 197 are for QZSS; 65 ~ 96 are for GLONASS(GL PRN); 01 ~ 36 are for Galileo(GA PRN). Maximally 12 satellites are included in each GSA sentence.
4	PDOP	1.2	Position dilution of precision (00.0 to 99.9)
5	HDOP	0.8	Horizontal dilution of precision (00.0 to 99.9)
6	VDOP	0.9	Vertical dilution of precision (00.0 to 99.9)
7	Checksum	36	

GSV – GNSS Satellites in View

Number of satellites (SV) in view, satellite ID numbers, elevation, azimuth, and SNR value. Four satellites maximum per transmission.

Structure:

```
$--GSV,x,x,xx,xx,xx,xxx,xx,...,xx,xx,xxx,xx *hh<CR><LF>
    1 2 3 4 5 6 7 4 5 6 7 8
```

Example:

```
$GPGSV,4,1,16,05,54,069,45,12,44,061,44,21,07,184,46,22,78,289,47*72<CR><LF>
$GPGSV,4,2,16,30,65,118,45,09,12,047,37,18,62,157,47,06,08,144,45*7C<CR><LF>
$GPGSV,4,3,16,14,39,330,42,01,06,299,38,31,30,256,44,32,36,320,47*7B<CR><LF>
$GPGSV,4,4,16,42,64,169,45,50,74,261,44,21,07,184,46,193,68,189,47*72<CR><LF>
```

Field	Name	Example	Description
1	Number of message	4	Total number of GSV messages to be transmitted (1-4)
2	Sequence number	1	Sequence number of current GSV message
3	Satellites in view	16	Total number of satellites in view (00 ~ 16)
4	Satellite ID	05	Satellite ID number, 01 ~ 32 are for GPS; 33 ~ 64 are for WASS(PRN minus 87); 193 ~ 197 are for QZSS; 65 ~ 96 are for GLONASS(GL PRN); 01 ~ 36 are for Galileo(GA PRN). Maximally 4 satellites are included in each GSV sentence.
5	Elevation	54	Satellite elevation in degrees, (00 ~ 90)
6	Azimuth	069	Satellite azimuth angle in degrees, (000 ~ 359)
7	SNR	45	C/No in dB (00 ~ 99) Null when not tracking
8	Checksum	72	

RMC – Recommended Minimum Specific GNSS Data

Time, date, position, course and speed data provided by a GNSS navigation receiver.

Structure:

```
$--RMC,hhmmss.sss,A,dddmm.mmmmm,a,dddmm.mmmmm,a,x.x,x.x,ddmmy,,a*hh<CR><LF>
```

1 2 3 4 5 6 7 8 9 10 11

Example:

```
$GNRMC,111636.932,A,2447.09495,N,12100.52235,E,000.0,000.0,030407,,A*61<CR><LF>
```

Field	Name	Example	Description
1	UTC time	0111636.932	UTC time in hhmmss.sss format (000000.000 ~ 235959.999)
2	Status	A	Status 'V' = Navigation receiver warning 'A' = Data Valid
3	Latitude	2447.09495	Latitude in dddmm.mmmmm format Leading zeros transmitted
4	N/S indicator	N	Latitude hemisphere indicator 'N' = North 'S' = South
5	Longitude	12100.52235	Longitude in dddmm.mmmmm format Leading zeros transmitted
6	E/W Indicator	E	Longitude hemisphere indicator 'E' = East 'W' = West
7	Speed over ground	000.0	Speed over ground in knots (000.0 ~ 999.9)
8	Course over ground	000.0	Course over ground in degrees (000.0 ~ 359.9)
9	UTC Date	030407	UTC date of position fix, ddmmyy format
10	Mode indicator	A	Mode indicator 'N' = Data not valid 'A' = Autonomous mode 'D' = Differential mode 'E' = Estimated (dead reckoning) mode
11	checksum	61	

VTG – Course Over Ground and Ground Speed

The Actual course and speed relative to the ground.

Structure:

\$--VTG,x.x,T,,M,x.x,N,x.x,K,a*hh<CR><LF>
 1 2 3 4 5

Example:

\$GNVTG, 000.0,T,,M,000.0,N,0000.0,K,A*3D<CR><LF>

Field	Name	Example	Description
1	Course	000.0	True course over ground in degrees (000.0 ~ 359.9)
2	Speed	000.0	Speed over ground in knots (000.0 ~ 999.9)
3	Speed	0000.0	Speed over ground in kilometers per hour (0000.0 ~ 1800.0)
4	Mode	A	Mode indicator 'N' = not valid 'A' = Autonomous mode 'D' = Differential mode 'E' = Estimated (dead reckoning) mode
5	Checksum	3D	

ZDA – Time & Date

UTC, day, month, year and local time zone.

Structure:

\$--ZDA,hhmmss.sss,xx,xx,xxxx,xx,xx*hh<CR><LF>
 1 2 3 4 5 6 7

Example:

\$GPZDA,052633.376,13,07,2012,00,00*51<CR><LF>

Field	Name	Example	Description
1	UTC time	0111636.932	UTC time in hhmmss.sss format (000000.000 ~ 235959.999)
2	Day	13	Day, 01 to 31
3	Month	07	Month, 01 to 12
4	Year	2012	Year in yyyy format
5	Local zone hours	00	Local zone hours, 00 to +/- 13 hrs
6	Local zone minutes	00	Local zone minutes, 00 to +59
7	checksum	51	

Contact Information Section

Contact : knc3@knctek.co.kr

Web Site: www.knctek.co.kr

Headquarter:

**6F03, Ace High-End Tower 6th, 60-25,
Gasan-dong, Geumcheon-gu
SEOUL, KOREA
TEL: 82-2-839-5701
FAX: 82-2-830-5703**